

AEV Critical Design Review

Team E

Jeremy Bresciani, Nolan Gilts, Kayley McCormick, Jake Weiner

Intro

- Design
- Performance
- Obstacles

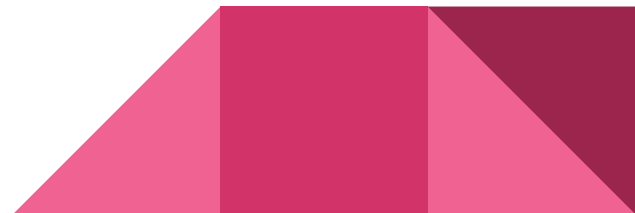

Design Process: Improving design and code

Moved to T Rocket design

- Less air resistance more aerodynamics
- Lighter
- Vertical design
 - Less air resistance
 - Ended up more balanced
- Additional Parts Added
 - Propeller was hitting the rail



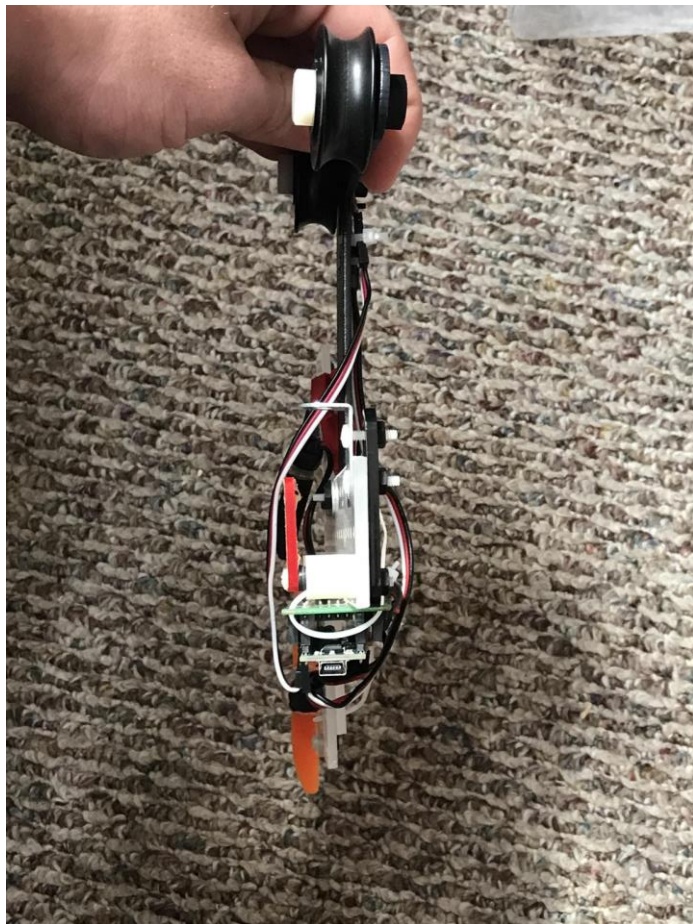
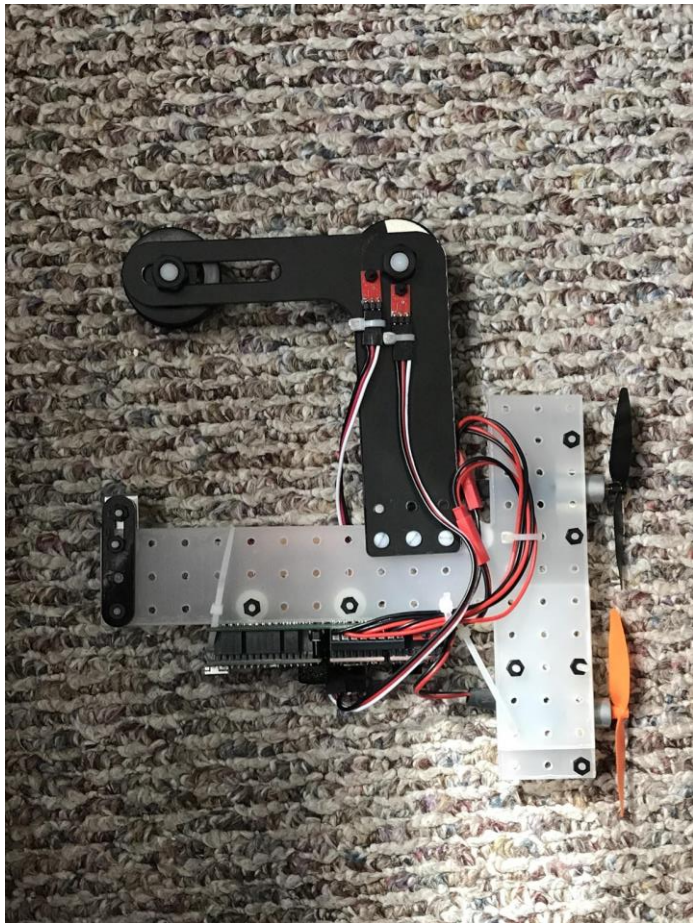

Screening Matrix

Criteria	Reference	Team Design A	Team Design B
Balance	0	-	0
Aerodynamics	0	+	0
Speed	0	+	+
Weight	0	+	+
Sum +'s	0	3	2
Sum 0's	4	0	2
Sum -'s	0	1	0
Net Score	0	2	2

Scoring Matrix

		Reference		Team Design A		Team Design B	
Criteria	Weight	Rating	Weighted Score	Rating	Weighted Score	Rating	Weighted Score
Balance	34	4	1.36	3	1.02	4	1.36
Aerodynamics	34	2	0.68	4	1.36	2	0.68
Speed	16	2	0.32	4	0.64	3	0.48
Weight	16	2	0.32	4	0.64	3	0.48
Total Score		2.68		3.66		3	

Performance of AEV

- Aerodynamics, Stability, and Speed
 - AEV structure
 - Battery relocation
- Efficient Energy Consumption
 - Energy Consumption Modifications
 - Coding

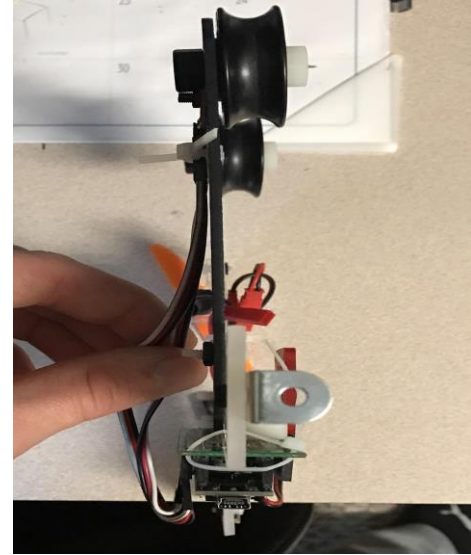

Performance of AEV

- Performance on Final Test
- Total energy usage
 - 314 Joules
- Energy mass ratio
 - 1.28

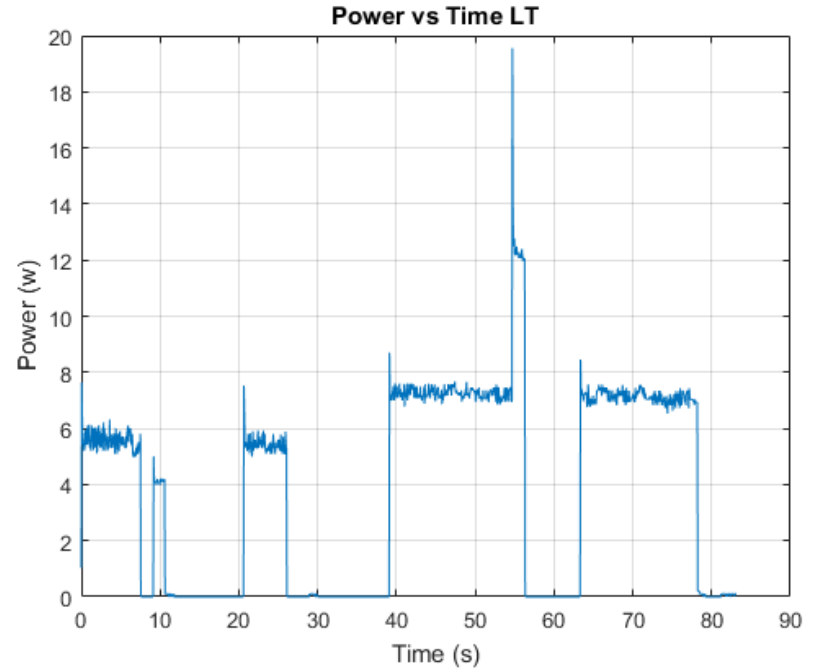

Final Design

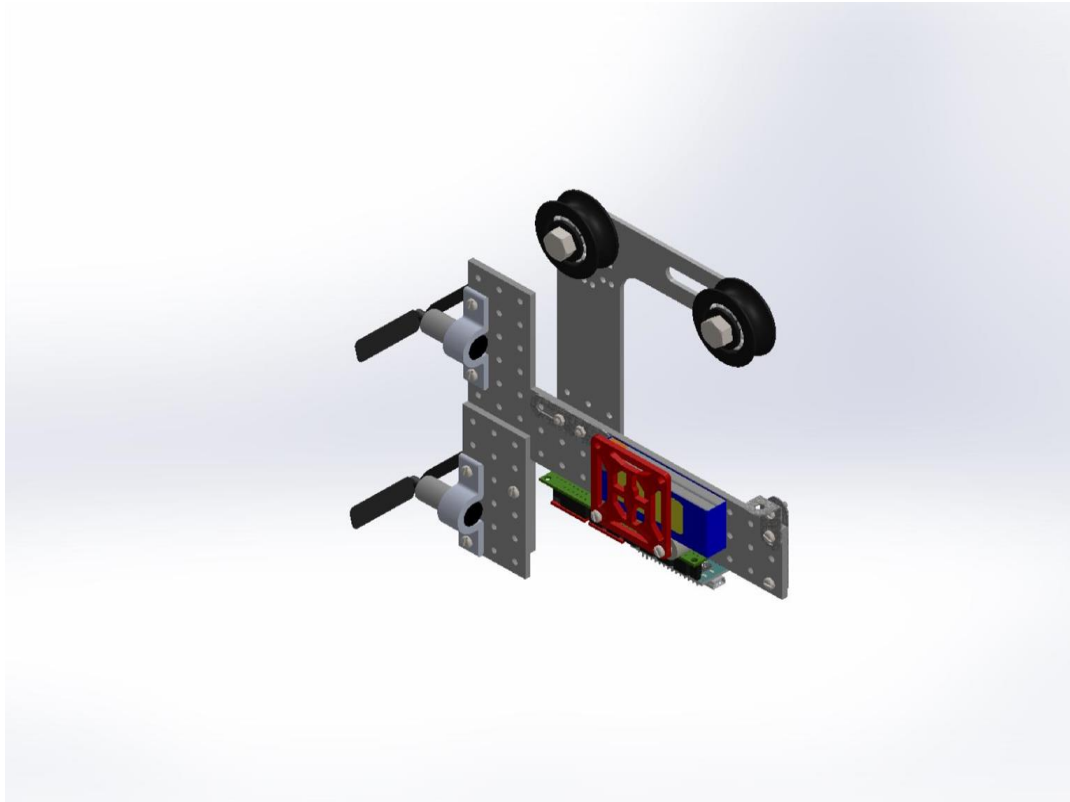

Final Design AEV on Track



Final design

- Obstacles that were overcome
 - How to stop the AEV
 - How to lower energy consumption
 - Propeller kept hitting the rail

- Final coding decisions
 - Coasting / blowback to stop AEV



The background is a solid pink color. In the top right corner, there is a decorative graphic consisting of several overlapping geometric shapes, including triangles and squares, in various shades of pink and magenta.

Questions?